



Drago America
www.dragoamerica.com

Project Name: _____

Location: _____

Item #: _____ Qty: _____

Model #: _____

SIA #

AIA #

Model:
DRCB52

Chef Base
9 ft³



Features & Benefits

Strong & Durable Structure

- Stainless steel interior and exterior.
- Matching aluminium finished back.

Temperature

- Temperature range 33°F ~ 40°F (0°C ~ 4°C).

User Friendly Features

- Preinstalled heavy-duty casters.
- Heavy-duty pull handles.
- Electronic control system; easy adjust temperature set point and defrost frequency.
- Easy access to condenser coil for cleaning and service.

Refrigerant R290.



Certifications



Drawers	HP	AMPS	Crated Weight	Dimensions (inches)		
				W	D	H
2	1/3	4.5	267 Lbs (121 Kg)	51.9" (1318 mm)	32.1" (880 mm)	25.9" (657 mm)

Packaging dimensions (mm): W 54.6" (1388) x D 34.6" (886) x H 28" (720)

Approvals:

Available At:

Model:
DRCB52

Chef Base
9 ft³



Front View

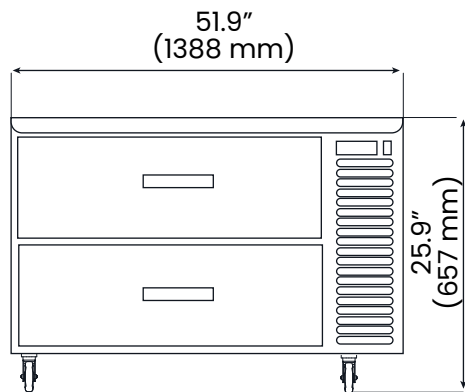

Side View

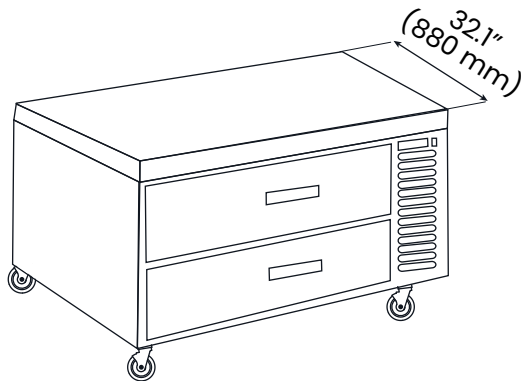

Electric Data

Electric Data	
Voltage	115/60/1
Plug Type	NEMA 5-15P
Compressor HP	1/3
Refrigerant	R290

Dimensional Data

Dimensional Data	
Capacity - cu. ft.	9 ft ³ (257 liters)
Net Weight - Lbs.	220 Lbs (100 Kg)

- Slight Variations May Exist



Drago America
www.dragoamerica.com
(346) 374-8343
9777 W. Gulf Bank Road Suite 200, Houston, Texas 77040